



Create a Beautiful Environment and a Fresh World



**Model: XJ70S**

## **User Manual**

**Machine Model: KR-XJ70S**

**Machine Name: Ride-on Floor Scrubber**

**Hefei Kuer Environmental Protection Technology Co. LTD**

**Please read this manual carefully before operation/please properly  
keep it**



**KR-XJ70S Ride-on Floor Scrubber**

## Warning

- ✧ Please read carefully and familiarize yourself with the contents of the manual before using the floor scrubber.
- ✧ This floor scrubber is only used for hard ground. If it is used for other purposes beyond the instructions in this manual, we will not bear any loss and responsibility caused thereby.
- ✧ During the operation of this floor scrubber, it is necessary to avoid winding long fiber substances such as ropes, corrosive chemicals, and high-temperature sundries. Otherwise, the brush may be damaged or other safety accidents might happen.
- ✧ This floor scrubber is designed to operate in dirty hard ground with various kinds of dirt.
- ✧ Any form of modification may affect its performance and service life, and even affect the safety of use, and may violate regulations. Damage caused by modification will not be covered by the warranty services of repair, replacement and refund.
- ✧ When the floor scrubber is turned on, do not put any part of the body into the rotating parts to avoid injury to the body caused by the rotation of the machine.
- ✧ The machine must be parked on a flat ground and should not be parked on a slope. Otherwise, it will cause other safety accidents.
- ✧ Disconnect the power supply of the floor scrubber before opening the hood, installing accessories, or maintenance and servicing.
- ✧ The floor scrubber should be charged in a well-ventilated place. If the battery is insufficient, the floor scrubber should be charged in time.
- ✧ When you finish your work, you should remove the key in time and keep it properly to avoid operation by unauthorized personnel.
- ✧ When the machine is shut down, all brushes and squeegees should be lifted to prolong the service life of consumables and maintain the machine.
- ✧ Do not flush the machine directly with a water cannon or high-pressure water cannon.
- ✧ Do not use the machine in a place with too much dust.
- ✧ The temperature for storage and operation of the machine is required to be 32°F to 104°F (0°C to +40°C).

## TABLE OF CONTENTS

<b>1. Performance parameters .....</b>	<b>3</b>
<b>2. Overall structure .....</b>	<b>3</b>
<b>3. Control System .....</b>	<b>4</b>
<b>4. Machine Commissioning and Pre-operation Check.....</b>	<b>6</b>
<b>5. Machine Operation .....</b>	<b>7</b>
<b>6. During Operation .....</b>	<b>8</b>
<b>7. After Operation .....</b>	<b>8</b>
<b>8. Cleaning System .....</b>	<b>9</b>
<b>9. Suction System .....</b>	<b>10</b>
<b>10. Waterway System .....</b>	<b>11</b>
<b>12. Troubleshooting .....</b>	<b>13</b>
<b>After-sales Statement .....</b>	<b>14</b>
<b>[Storage Battery Maintenance Guide] .....</b>	<b>15</b>
<b>Product Warranty Certificate (Main Card).....</b>	<b>17</b>
<b>Product Warranty Certificate (Secondary Card).....</b>	<b>18</b>

## 1. Performance Parameters

Model	Unit	70S
Overall size (L*W*H)	mm	1300*920*1130
Weight (with the battery weight included)	KG	238
Voltage	V	12
Cleaning width	mm	700
Vacuum suction	KPA	220mbar
Drive motor	W	400
Brush motor	W	2*400
Suction motor	W	500
Squeegee width	mm	920
Charging time	H	8-10
Solution tank capacity	L	70
Recovery tank capacity	L	75
Brush pressure	KG	26
Number of brushes	inch	13"*2
Grade ability (no load)	%	≈25

## 2. Overall Structure



### 3. Control System

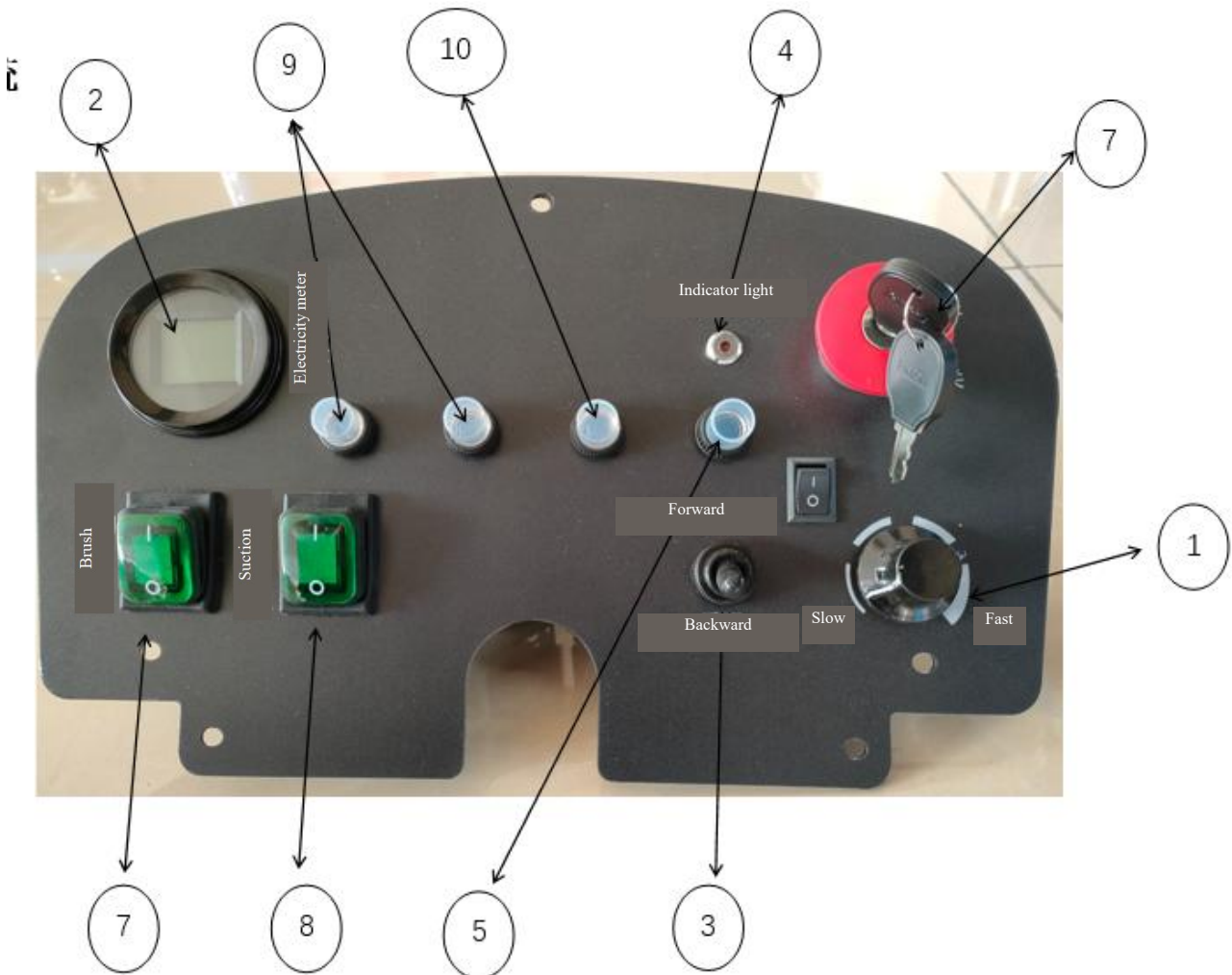

1. Speed control switch
2. Battery meter
3. Forward and backward switch
4. Fault indicator
5. Overload reset switch
6. Brush lifting switch
7. Power switch
8. Squeegee lift switch
9. Brush system fuse
10. Suction system fuse

(1) Power key switch: when the key is turned to ON, the machine power is on, and when the key is turned to OFF, the power is off.

(2) Adjust the forward and backward buttons to the forward gear (the machine will not go backward when the brush and squeegee are on the ground).

(3) Power display: it displays the current power of the storage battery. As long as the machine is turned on, this light must be on. The power meter displays the power from right to left, that is, the rightmost indicates the highest voltage. When the voltage is as low as 10V, the brush, air suction,

and water spraying functions are stopped, but the driving function is retained. When the voltage is lower than 8V, all functions of the machine stop working.

(4) Brush button: after pulling the brush button forward, the brush will slowly fall, and after pulling it backward, the brush will slowly rise.

(5) Suction button: after pulling the suction button forward, the squeegee will drop and the water suction motor will start, and after pulling it backward, the squeegee will rise, and the suction motor will be off.

(6) Horn switch: the horn switch is in the middle of the steering wheel. When it is pressed down, the horn will sound, but when it is released, it will not sound.

(7) Emergency stop switch: press this switch to power off the control system. When the emergency stop button is pulled up, the control system will be powered on.

### **Warning!!**

- After completing the work, the brush parts should be lifted to prevent the brushes from being deformed and worn.
- After the completion of the work, the squeegee parts should be lifted to prevent the deformation of the suction rubber strip.
- Do not park the floor scrubber on the slope.
- The machine cannot climb the slope more than 25%, and there must be no stored water in the solution tank and the recovery tank.

## **4. Machine Commissioning and Pre-operation Check**

### **4.1 Pre-operation check**

1. Check whether the appearance is clean. Note: Please do not use the machine in a flammable and explosive environment.
2. Check whether the storage battery wiring is in good contact to prevent short circuit fault.
3. Turn on the machine with the key and check whether the power is sufficient. If the power is too low, please do not continue to use the machine. Turn off the power immediately and charge the storage battery. Make sure the storage battery is fully charged before use.
4. Check whether the brush or micropositioner is installed correctly.
5. Check whether the squeegee is installed correctly (the rubber strip has been installed).
6. Ensure that the dirt in the recovery tank is removed.

### **4.2 Machine commissioning**

#### **4.2.1 Brush installation**

1. Ensure that the machine is stationary.
2. Take out the attached brush, align the brush buckle with the flange buckle under the brush motor, rotate the brush to the left and right respectively by hand to connect the flange buckle. If the brush does not fall when both hands leave the brush, it means that the brush is connected with the flange buckle.
3. If a micropositioner is required, first place the fiber pad on the micropositioner, and then install in the way the same as that of brush.

#### **4.2.2 Squeegee assembly installation**



1. First lift the fixed plate assembly of the squeegee off the ground.
2. Unscrew the two black cross bolts in the middle of the squeegee assembly, and place the squeegee assembly in the fixed slot of the squeegee fixed plate.
3. Insert the suction hose into the corresponding opening of the squeegee assembly. (See the corresponding schematic diagram of the whole machine structure)
4. Press the suction button, put the locked squeegee assembly on the ground, check whether the rubber strip is pressed on the ground reasonably, and make appropriate adjustments.

#### 4.2.3 Water injection in solution tank

The fresh water filling port is located at the left rear of the whole machine, pick up the filler cover and add fresh water into the water tank.

#### **Note!!**

**When using a bucket to fill water, make sure the bucket is clean. To add detergent, please contact your local agent.**

## **5. Machine Operation**

After the check, the work can be started.

1. Check the water volume according to the water volume of the hose. If the water volume is insufficient, add an appropriate amount of water before starting the work;
2. Cover the water tank cover and ensure that the water tank cover covers properly to form a preliminary seal;
3. Cover the sewage pipe cover and put it in the clamp of the sewage pipe;
4. Adjust the water volume according to the dryness of the ground, and adjust it to the appropriate water volume;
5. Take the driver's seat and adjust the appropriate operating position;
6. Turn on the key to keep the machine powered on.
7. The panel indicator light is on, the forward and backward switch is turned to forward, and the speed switch is turned to the minimum speed (leftmost).
8. After pulling the brush and suction switch forward and putting down the squeegee and brush, the suction motor works. After stepping on the pedal switch, the brush works and the solenoid valve is opened. At this time, slowly increase the speed. The whole machine moves forward and starts to work.
9. To stop cleaning, first turn off the brush button, lift the brush and disconnect the solenoid valve. After moving forward for 5s, turn off the suction button until the sewage is discharged, and clean the recovery tank and squeegee. After that, stop the machine, adjust the speed to the slowest, press the key switch and pull out the key. If the power meter points to the middle position, the machine should be charged.

#### **Recommendation!!**

- ◆ When this floor scrubber works, it is best for it to clean at a speed of 80 to 90m per minute.

#### **Note!!**

- ◆ When the machine is in the reverse state, the squeegee will be automatically lifted up, and the suction motor will not work.

## 6. During Operation

1. When working on slopes or slippery ground, the machine should work at low speed and should not work on slopes more than 3°.
2. After the machine moves, keep it walking to avoid damaging the ground.
3. If the suction assembly leaves drag marks on the ground after absorbing water, please wipe the scraping strip with a rag to remove garbage. (Please clean the area to be cleaned in advance to avoid drag marks.)
4. If there is too much foam in the recovery tank, please pour defoaming liquid into the recovery tank in time for defoaming. (Please contact the local agent) In the process of use, you should always observe the power meter. When the voltage is as low as 20.2V, stop brush, air suction and water spray. In this way, the drive can still move forward. When the voltage is lower than 20V, all functions of the machine stop working. (Please predict in advance)
5. When the sewage in the recovery tank is full, the suction motor stops working. At this time, drain the sewage and fill up with clean water.

### **Note!!**

**When the sewage in the recovery tank is full, the suction motor stops working.**

#### 6. After Operation

##### 7.1 Recovery tank drainage

After each cleaning, or before adding water to the solution tank again, the sewage in the recovery tank should be drained and the solution tank should be cleaned.

1. Take out the sewage pipe, pull out the cover of the sewage pipe, and put the sewage pipe into the drainage bucket or drain to start drainage.
2. Open the cover of the recovery tank and flush the inside of the recovery tank with clean water.
3. Clean the floater filter screen in the recovery tank.
4. Clean the water full protector in the recovery tank.

### **Warning!!**

◆ When the solution tank is filled with water again, if the recovery tank is not drained, foam or water may enter the floater and damage the suction motor.

#### 7.2 Solution tank drainage

After each cleaning, the solution tank should be drained and cleaned.

1. Turn on the ball valve switch next to the left rear wheel of the solution tank to drain out all the clean water in the solution tank.
2. Unscrew the transparent cover of the filter assembly to drain the clean water in the solution tank. Please clean the filter screen in the filter.

### **Note!!**

◆ When the solution tank is filled with water again, if the recovery tank is not drained, foam or water may enter the floater and damage the suction motor.

#### 7.3 Storage battery charging

1. Place the battery charger and the machine in a well-ventilated place.
2. Turn off the machine.
3. Plug the AC power cord of the charger into the power socket well grounded.
4. Plug the DC output of the charger into the charging port on the front column of the machine. (See

the corresponding schematic diagram of the whole machine structure)

5. The battery charger starts charging automatically. If the battery is fully charged, the charger will be automatically turned off.

6. At the end of charging, first unplug the plug connected to the AC power supply, and then unplug the output end of the charger from the machine.

### Warning!!

◆ When charging the machine, you must use the original charger supplied with the machine.

## 8. Cleaning System

The cleaning system is a complete cleaning system composed of motor, scrubbing brush and sprinkler system. (Figure 8.1)

### Warning!!

◆ **Do not stay the machine at the same place to rotate the brush when starting the machine for cleaning. If the machine stays at the same place for a long time, the ground will be damaged by brushing, as shown in Schematic Diagram 8.1.**



1. Brush motor: mainly used for driving the rotation of brush ground cleaning.

2. Scrubbing brush: mainly used for cleaning and decontamination of various conventional grounds.

3. Lifting mechanism: mainly used for the rotation of lifting and lowering of the entire cleaning system.

4. Water retaining rubber: prevent the second pollution caused by sewage thrown out during cleaning

### 8.2 Operation method

The brush lifting mechanism of this floor scrubber is provided with a push rod motor to control the lifting system with one key.

After pulling the brush button forward, the brush slowly drops. After pulling the brush button backward, the brush slowly rises. When the brush button is pressed, the brush push rod motor is started and the brush assembly is lowered. When the brush assembly drops to the ground, step on the pedal switch to start the rotation of the brush.

### 8.3 Check and maintenance

	Problem	Cause	Solution
1	The brush swings left and right obviously	The set screw of the rotating rod is loose	Tighten the set screw
2	Both sides of the brush are uneven	The set screw of the rotating rod is loose	Tighten the set screw

## 8.4 Maintenance mode

1. When the floor scrubber is stationary for a long time, the scrubbing brush should be lifted to avoid deformation of the bristles, which will affect the next cleaning effect.
2. During the cleaning, the metal entanglements on the bristles should be removed in time to reduce the load of the brush motor, avoid damaging the consistency of the ground and improve the overall working efficiency.
3. Avoid cleaning lime, cement, sulfuric acid and other objects that are easy to solidify, corrode and combust.

## 9. Suction System

### 9.1 Schematic diagram

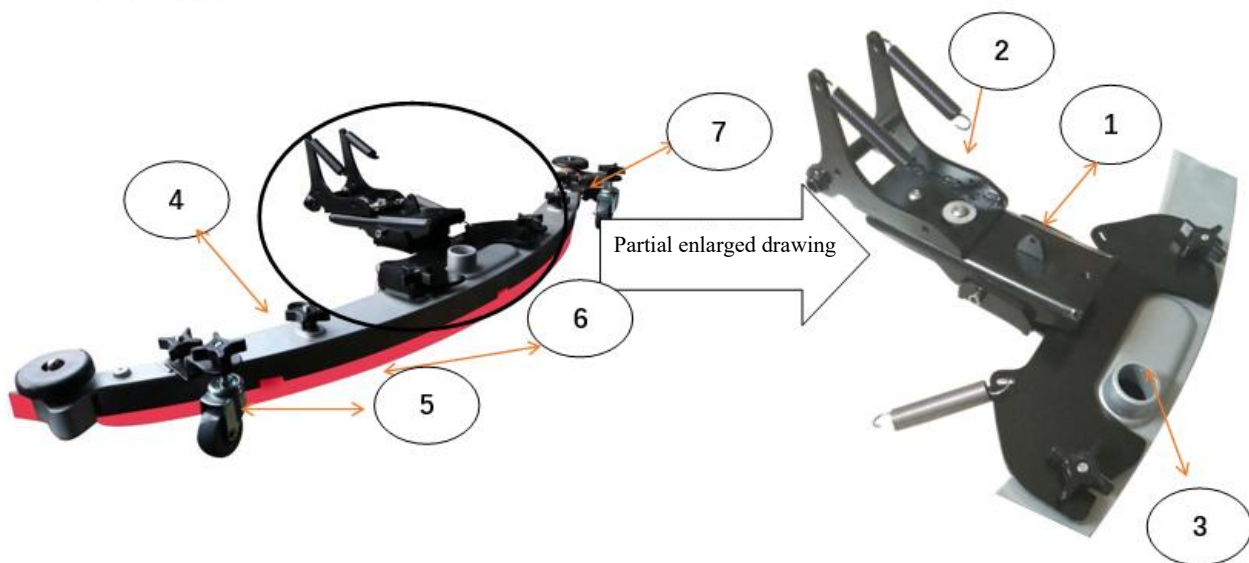

1. Squeegee connecting base: it is directly connected to the lifting motor chain, and mainly plays the role of lifting the squeegee assembly.
2. Squeegee rotating frame: it is used as a conduction bridge for straight travel, turning and return of squeegee assembly.
3. Sewage suction pipe port: it is an important part of sewage suction, connecting the squeegee assembly and the recovery tank hose.
4. Squeegee assembly: it is an important part for sewage collection.
5. Supporting universal wheel: it is used for height adjustment of squeegee rubber strip. The wheel has been adjusted to the best value before factory.
6. Rear suction rubber strip: it is a consumable part. Please replace and maintain it as required.

### 9.2 Operation method

The suction lifting mechanism of this floor scrubber is provided with a push rod motor to control the lifting system with one key.

When the suction button is pressed, the suction push rod motor starts and lowers the squeegee assembly, and the suction motor starts to work.

### 9.3 Squeegee commissioning

With the extension of service time of squeegee, the wear of the rubber strip will have a certain impact on the suction effect. In order to completely remove the stains, the following corresponding commissioning is required.

1. Adjust the height of the two supporting universal wheels behind the squeegee to be the same. When the squeegee is stationary, it needs to be suspended from the ground for about 2mm to 3mm.
2. Rotate the four-corner handle nut until the rear rubber strip is tightly pressed against the ground.

## 9.4 Rubber strip replacement

The rubber strip is rectangular and should be replaced after both sides are fully used.

1. First, loosen the pressing plate pressed on the front and rear rubber strips.
2. Then remove the front and rear rubber strips.
3. Take out the new rubber strip required.
4. Install the new rubber strip in the order when the old rubber strip is removed.

### Maintenance Note!!

After each floor cleaning, the squeegee assembly needs to be lifted and the rubber strip needs to be cleaned.

## 10. Waterway System

### 10.1 Schematic diagram

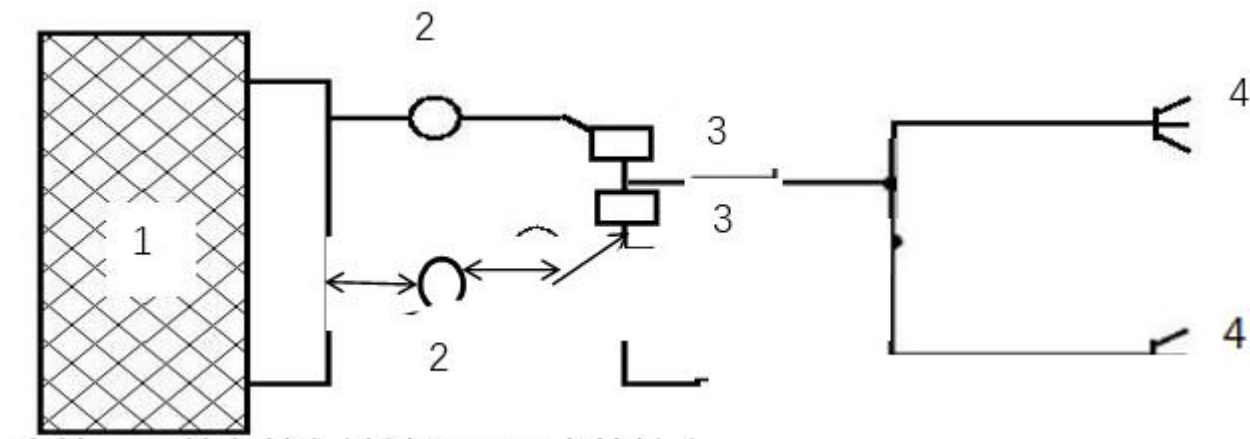

1. Solution tank: it is one of the core accessories of the machine for storing water for cleaning the ground.
2. Filter: it is installed on the left and right sides of the drive wheel in front of the solution tank to filter impurities in the waterway system.
3. Solenoid valve: one is installed on the left and right symmetrical sides of the upper part of the brush assembly respectively to control the water volume and close the water volume.
4. Water outlet: it is located in the middle of the brush to supply water during the brush cleaning.

### 10.2 Operation method

The waterway system and the cleaning system are designed to work synchronously.

While the brush is working, the solenoid valve is open. While the brush is not working, the solenoid valve is closed, and the ball valve adjusts the water volume separately.

### 10.3 Check and maintenance

Problem	Cause	Solution

1	No water out of the water outlet	Blockage of filter	Clean the filter screen
2		The solenoid valve is not opened	Check whether there is foreign matter blockage, whether the circuit is short circuited, etc.
3		The main ball valve is not opened	Turn on the ball valve switch
4		Water outlet blockage	Remove sundries at the water outlet (water outlet of solution tank)
5	Too small water flow	There is air inside the water pipe	Remove the water pipe and exhaust the air
6		The water pipe is bent	Adjust the water pipe to be bent
7		The ball valve is not sufficiently opened	Wide open the ball valve

### 11.1 Regular maintenance

Regular maintenance and check		Interval time				
		4	20	50	200	500
1	Battery power detection	√				
2	Carbon brush check of motor					√
3	Whether the brush is wired or entangled with silk	√				
4	Check the clean water filter		√			
5	Check the instrument panel and various electronic switches					√
6	Check the wear of the brush			√		
7	Clean the upper and lower water tanks in time	√				
8	Check the wear of the suction rubber		√			
9	Check the use of suction hose and drain hose	√			√	
10	Check the clean water effluent	√				
11	Check the squeegee suction	√				

### 11.2 Storage battery maintenance

The floor scrubber system is powered by 2 X 6V maintenance-free storage batteries in series, and the system voltage is 12V.

1. When the machine operates for a period of time, the storage battery power will drop. When the last bar of the power display meter flashes, it indicates that the power is insufficient and charge is needed in time.
2. When maintaining the storage battery, please wear protective gloves to avoid contact with storage battery acids.

3. The top of the storage battery and the electrode must be treated to prevent corrosion, that is, wipe repeatedly with a brush stained with soda water, but do not pour this solution into the battery.
4. Check whether the storage battery connection is worn and whether the contact parts are loose, and replace if necessary.
5. The power output terminal on the battery should be kept clean and dry, and there should be no sundries, dust and soil on it because it is not only extremely detrimental to the battery, but also shortens the service life of the battery and even burns the battery.

**Note!!**

◆ In order to make the storage battery have a long service life, the battery should be charged in time after the operation of the machine, but should not be discharged for a long time.

**Warning!!**

◆ During the use of the battery, the deep discharge battery capacity will be reduced and the service life will be shortened.

◆ Since the battery will release hydrogen, the battery box must be kept open during charging and away from sparks or fire sources to prevent the hydrogen released by the battery from causing danger.

**12. Troubleshooting**

Problem	Cause	Solution
No water out of the brush	Waterway blockage	Check and dredge the waterway
	Less water in the water tank	Fill the water tank with water
	Solenoid valve fault	Replace solenoid valve
Shutdown of brush motor	The brush motor is damaged.	Replace
	The wire harness connector is loose or damaged	Repair or replace
	Panel switch fault	Replace
Shutdown of suction motor	The suction motor is damaged	Replace
	The wire harness connector is loose or damaged	Repair or replace
	Panel switch fault	Replace
Water marks during	Foreign matters are stained at the suction rubber strip	Eliminate foreign matters

suction	The suction rubber strip is not tightened or wrinkled	Reinstall the rubber strip
Insufficient suction or inability to absorb suck	The cover of recovery tank is not covered properly	Cover the recovery tank
	The seal ring of the cover is damaged	Replace the seal ring
	The cover of the sewage pipe is not covered properly	Cover the drain pipe
	The recovery tank is full of sewage	Drain the sewage
	The suction hose is blocked	Clean the suction hose
Water cannot be sucked completely	The suction rubber strip is worn	Replace the rubber strip
	There is a gap between the squeegee and the ground	Adjust the ground clearance of the squeegee universal wheel
	The angle of the rubber strip behind the squeegee is too large	Adjust the angle of rubber strip behind the squeegee
The vehicle cannot drive	Over speed protection	Release the foot pedal, let it return and turn off the power, turn on the power again, and then press the foot pedal to start the floor washing car after resetting
	Oxidation (corrosion) of power terminals	Disconnect the power, remove the nut, clean the terminals and reinstall.
	The storage battery is low	Charge
	Proximity switch	Replace
	Loose electrical harness connector	Repair or replace

### After-sales Statement



The Company has a perfect after-sales service system and customer satisfaction sales commitment.

1. From the date of purchase, except for vulnerable and consumable parts, other major parts of the machine are guaranteed for one year.
2. When sending for repair, the user must hold a valid purchase invoice and product warranty card for the product sent for repair, and the warranty period shall be calculated from the date when the invoice is issued. The user should properly keep the warranty card and purchase invoice. If the user loses the purchase invoice due to their own reasons, the validity period shall be calculated according to the factory date.
3. According to the national regulations, free warranty will not be provided under the following circumstances.
  - The damage is caused by improper handling, installation, use, maintenance and storage of the user.
  - There are no warranty certificate and valid procurement invoice.
  - The warranty certificate number is inconsistent with the entity product code or altered.
  - The product is damaged due to force majeure.
  - The free warranty period has expired.
4. The product damage caused by accident, abuse and negligence or part damage caused by incorrect use is not included in the warranty terms, and the Company is not responsible for any direct or indirect losses caused thereby.

For the products that exceed the warranty period or are not within the scope of free warranty, we will be very pleased to serve you.

All the cleaning equipment and machinery supplied by the Company have passed the ex-factory inspection and have good performance. In order to ensure no damage during the transport and avoid unnecessary misunderstanding, they will be inspected by local distributors before selling. Please refer to the instructions before use.

You need to provide the procurement receipt when you request our warranty service, thank you for your cooperation!

### **[Storage Battery Maintenance Guide]**

Lead-acid battery is used in this product, which is provided with the maintenance-free, servicing-free and automatic pressure relief functions; You should charge it as you use it, or immediately charge it after use and do not discharge frequently (minimum protection voltage).

- 1) What is short circuit, and how does it affect the battery performance?

Short circuit refers to that the positive and negative electrodes of the battery are connected to produce strong current; and the internal positive and negative electrode groups are connected. The voltage rises very slowly and remains low during charge; the electrolyte temperature rises very high and rapidly; the electrolyte density rises very slowly or hardly changes; and the terminal voltage drops rapidly during the current discharge.

- 2) What is over-discharge, and how does it affect the battery performance?

Over-discharge refers to the phenomenon that the electric quantity stored in the battery continues to discharge after reaching the minimum operating voltage during discharge. After the battery is over-discharged, the voltage drops sharply in a very short time. At this time, the reaction system in the whole battery is disordered. If the battery is over-discharged repeatedly, the positive electrode

will lose its activity, which will affect the service life of the battery, reduce the use time of the battery, and extend the charging time of the battery.

3) How to store the battery after use?

The battery is a sensitive product. If it is no longer used for a long time, it is best to take the battery out of the machine and put it in a dry place at normal temperature; Because the battery is placed inside the machine, and the electrical appliance and circuit board are not disconnected, continuous micro-discharge of the battery will be formed.

4) Why is the service life of the battery short?

The battery is not fully charged for a long time, and it will not be charged for a long time after being discharged. During use, the phenomenon of over-discharge often occurs. The standard charger is not selected during the charge, resulting in overcharge. The voltage between the used battery packs is different, forming a low-voltage operating state for a long time.

## Product Warranty Certificate (Main Card)

(This warranty card is the main certificate of warranty service, please keep it properly.)

### Warranty regulations:

During the warranty period, faults arising from normal use according to the instruction manual will be repaired free of charge. Please send the product to be repaired with this warranty certificate and invoice to the seller for repair free of charge.

**Please kindly understand that, during the warranty period, repair must be charged in the case of one of the following circumstances:**

1. The original warranty certificate and valid invoice cannot be provided.
2. Faults or damages are caused by wrong use and improper repair or modification.
3. Failures or damages are caused by transportation, handling or falling after purchase.
4. Failures or damages are caused by using power sources other than those specified (voltage, frequency, etc.) or abnormal voltages.
5. Machine appearance, or accessories such as dust-proof piece, filter element, electric wire, hose and steel pipe.

**During the period stipulated in this warranty, repair will be provided free of charge according to the above agreed conditions. The warranty does not extend to other losses caused by the failures.**

User name:

Address:

Invoice number:

Date of purchase:

Seller:

Address:

## Product Warranty Certificate (Secondary Card)

### 1. Product information:

Product model and name: \_\_\_\_\_

Ex-factory No.: \_\_\_\_\_

### 2. User information:

End user: \_\_\_\_\_ Tel: \_\_\_\_\_

Address: \_\_\_\_\_ Fax: \_\_\_\_\_

E-mail: \_\_\_\_\_ Postal code: \_\_\_\_\_

### 3. Information of the sale organization: \_\_\_\_\_

Seller's name: (valid with seal)

Address: \_\_\_\_\_

Contact person: \_\_\_\_\_ Tel: \_\_\_\_\_

Postal code: \_\_\_\_\_ Sale date: \_\_\_\_\_

**In order to honor the Company's service commitments and relieve worries of users with excellent service, the Company will establish user information files in the Customer Service Computer System.**

1. Please be sure to complete the main card and the secondary card of the warranty certificate as soon as possible, and return the secondary card to the Customer Service Department of the Company for filing within 1 month of the purchase of the machine. The mailing address is as follows:

2. If the main card of the warranty certificate or the voucher of purchase of the machine is lost, you may check the Company's User Information Files for all services available.



**Create a Beautiful Environment and a Fresh World**

## **Hefei Kuer Environmental Protection Technology Co. LTD**

Address: No. 11, Cuizhu Road, Taohua Town, Feixi County, Hefei, Anhui Province

Website: <https://www.kuerclean.com>

TEL/Whatsapp: 8617352967132

E-mail: [info@kuerclean.com](mailto:info@kuerclean.com)

Due to the continuous update of this product,  
the specific parameters of the material object should prevail